

Features

- Guard Ring Die Construction for Transient Protection
- Low Power Loss, High Efficiency
- Low Forward Voltage Drop
- Low Reverse Leakage Current
- For Use in Low Voltage, High Frequency Inverters, Free Wheeling, and Polarity Protection Applications
- High Forward Surge Current Capability
- **Lead Free Finish, RoHS Compliant (Note 1)**
- **"Green" Molding Compound (No Br, Sb)**
- **Qualified to AEC-Q101 Standards for High Reliability**

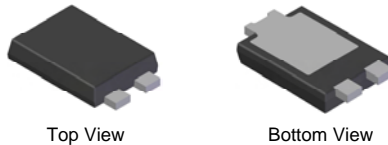

Top View

Bottom View

Mechanical Data

- Case: PowerDI[®]5
- Case Material: Molded Plastic, "Green" Molding Compound. UL Flammability Classification Rating 94V-0
- Moisture Sensitivity: Level 1 per J-STD-020D
- Terminals: Finish – Matte Tin annealed over Copper leadframe. Solderable per MIL-STD-202, Method 208 **(e3)**
- Polarity: See Diagram
- Marking Information: See page 3
- Ordering Information: See page 3
- Weight: 0.093 grams (approximate)

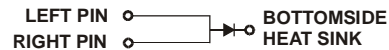

Note: Pins Left & Right must be electrically connected at the printed circuit board.

Maximum Ratings @ $T_A = 25^\circ\text{C}$ unless otherwise specified

Single phase, half wave, 60Hz, resistive or inductive load.
 For capacitance load, derate current by 20%.

Characteristic	Symbol	Value	Unit
Peak Repetitive Reverse Voltage	V_{RRM}	40	V
Working Peak Reverse Voltage	V_{RWM}		
DC Blocking Voltage	V_R		
RMS Reverse Voltage	$V_{R(RMS)}$	28	V
Average Rectified Output Current (See also Figure 5)	I_O	3	A
Non-Repetitive Peak Forward Surge Current 8.3ms Single half sine-wave Superimposed on Rated Load	I_{FSM}	90	A

Thermal Characteristics

Characteristic	Symbol	Typ	Max	Unit
Thermal Resistance Junction to Soldering Point	$R_{\theta JS}$	—	6.0	$^\circ\text{C/W}$
Thermal Resistance Junction to Ambient Air (Note 2) $T_A = 25^\circ\text{C}$	$R_{\theta JA}$	95	—	$^\circ\text{C/W}$
Thermal Resistance Junction to Ambient Air (Note 3) $T_A = 25^\circ\text{C}$	$R_{\theta JA}$	60	—	$^\circ\text{C/W}$
Thermal Resistance Junction to Ambient Air (Note 4) $T_A = 25^\circ\text{C}$	$R_{\theta JA}$	50	—	$^\circ\text{C/W}$
Operating and Storage Temperature Range	T_J, T_{STG}	-65 to +150		$^\circ\text{C}$

Electrical Characteristics @ $T_A = 25^\circ\text{C}$ unless otherwise specified

Characteristic	Symbol	Min	Typ	Max	Unit	Test Condition
Reverse Breakdown Voltage (Note 5)	$V_{(BR)R}$	40	—	—	V	$I_R = 0.5\text{mA}$
Forward Voltage	V_F	—	0.45	0.49	V	$I_F = 3\text{A}, T_J = 25^\circ\text{C}$
		—	0.38	0.42		$I_F = 3\text{A}, T_J = 125^\circ\text{C}$
		—	0.53	0.61		$I_F = 6\text{A}, T_J = 25^\circ\text{C}$
		—	0.50	0.57		$I_F = 6\text{A}, T_J = 125^\circ\text{C}$
Reverse Current (Note 5)	I_R	—	15	500	μA	$T_J = 25^\circ\text{C}, V_R = 40\text{V}$
		—	3	20	mA	$T_J = 100^\circ\text{C}, V_R = 40\text{V}$
		—	10	25	mA	$T_J = 125^\circ\text{C}, V_R = 40\text{V}$

- Notes:
1. EU Directive 2002/95/EC (RoHS). All applicable RoHS exemptions applied, see *EU Directive 2002/95/EC Annex Notes*.
 2. FR-4 PCB, 2 oz. Copper, minimum recommended pad layout per <http://www.diodes.com/datasheets/ap02001.pdf>.
 3. Polyimide PCB, 2 oz. Copper, minimum recommended pad layout per <http://www.diodes.com/datasheets/ap02001.pdf>.
 4. Polyimide PCB, 2 oz. Copper. Cathode pad dimensions 6.5mm x 5.0mm. Anode pad dimensions 1.8mm x 1.1mm.
 5. Short duration pulse test used to minimize self-heating effect.

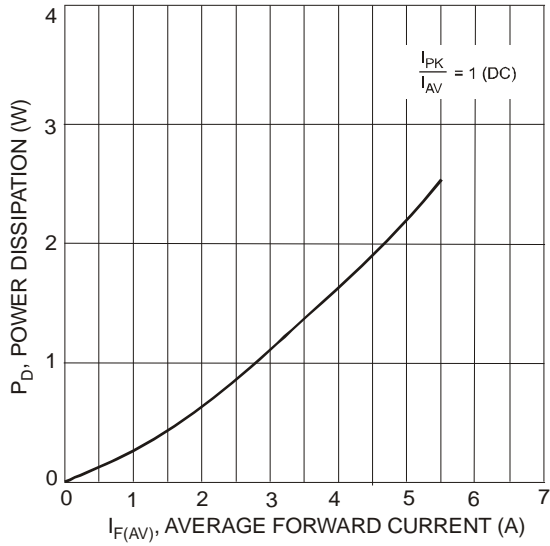

Fig. 1 Forward Power Dissipation

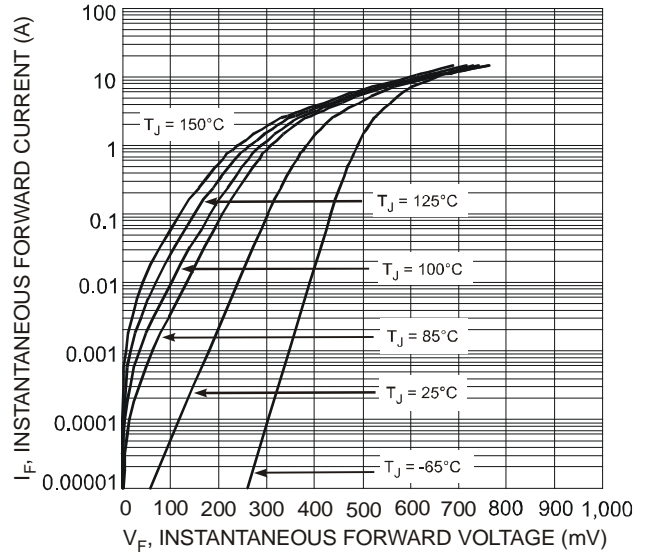

Fig. 2 Typical Forward Characteristics

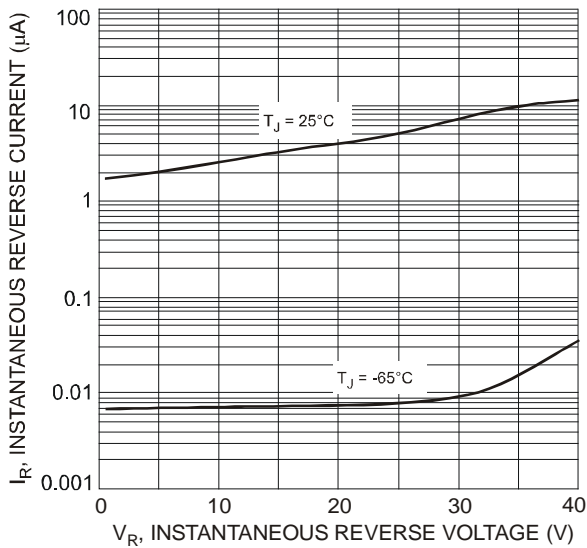

Fig. 3 Typical Reverse Characteristics

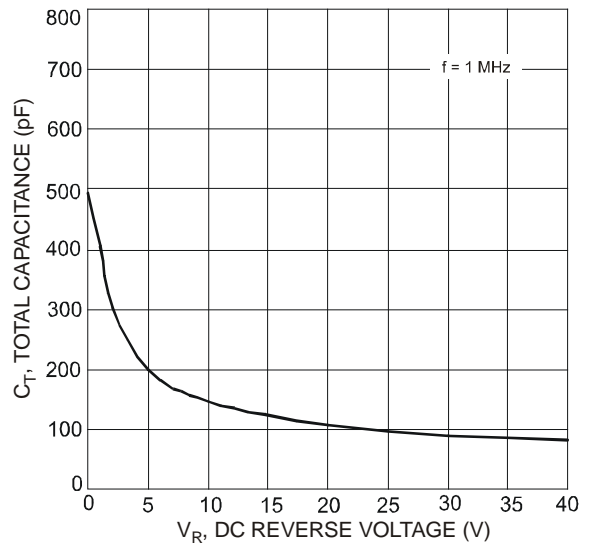

Fig. 4 Total Capacitance vs. Reverse Voltage

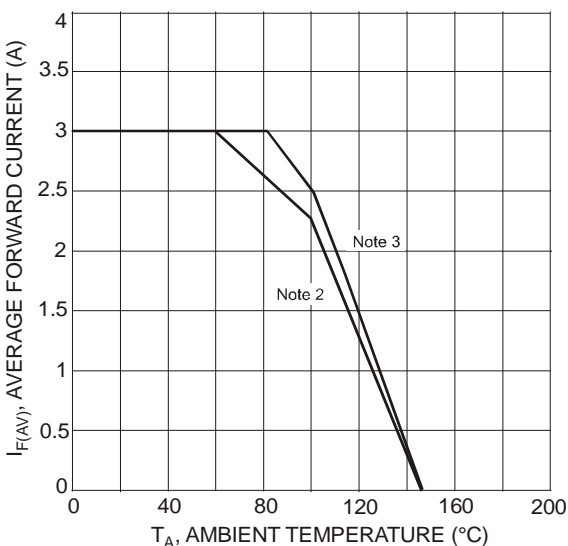

Fig. 5 Forward Current Derating Curve

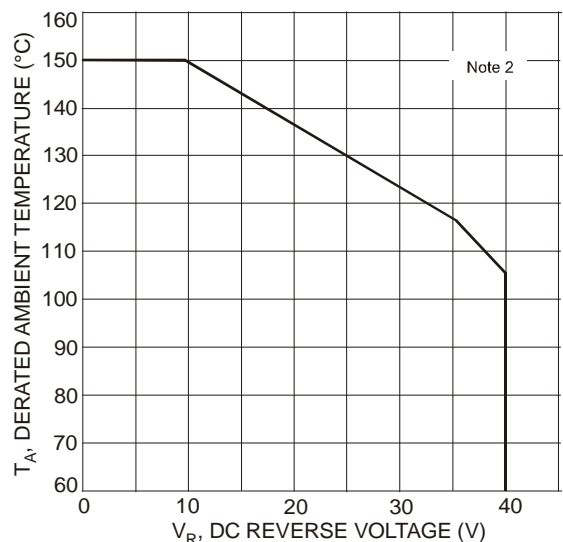

Fig. 6 Operating Temperature Derating

PowerDI is a registered trademark of Diodes Incorporated.

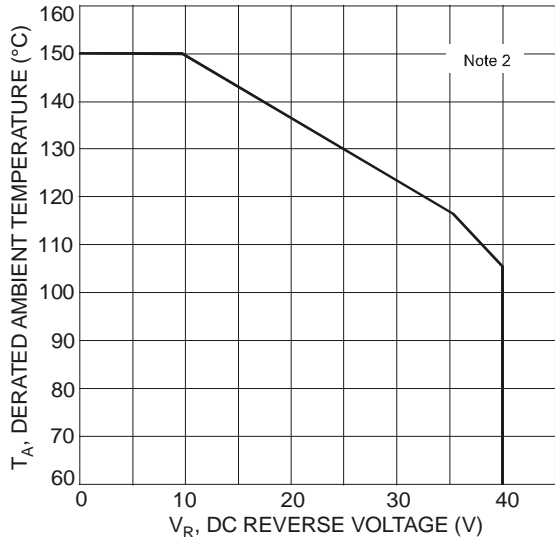

Fig. 7 Operating Temperature Derating

Ordering Information (Note 6)

Part Number	Case	Packaging
PDS340-13	PowerDI [®] 5	5000/Tape & Reel

Notes: 6. For packaging details, go to our website at <http://www.diodes.com/datasheets/ap02007.pdf>.

Marking Information

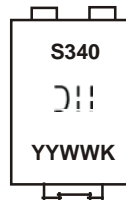

S340 = Product type marking code
 DII = Manufacturers' code marking
 YYWW = Date code marking
 YY = Last digit of year ex: 04 for 2004
 WW = Week code 01 to 52
 K = Factory Designator

Package Outline Dimensions

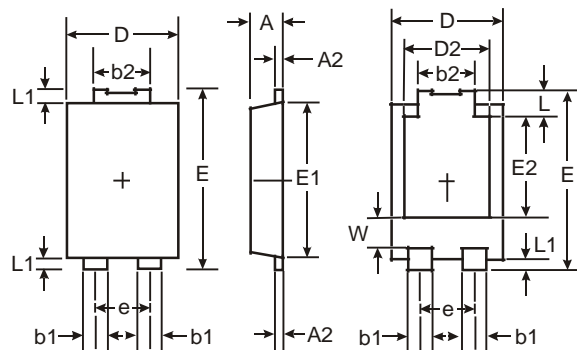

PowerDI [®] 5		
Dim	Min	Max
A	1.05	1.15
A2	0.33	0.43
b1	0.80	0.99
b2	1.70	1.88
D	3.90	4.05
D2	3.05 NOM	
E	6.40	6.60
e	1.84 NOM	
E1	5.30	5.45
E2	3.55 NOM	
L	0.75	0.95
L1	0.50	0.65
W	1.20	1.50
All Dimensions in mm		

PowerDI is a registered trademark of Diodes Incorporated.

Suggested Pad Layout

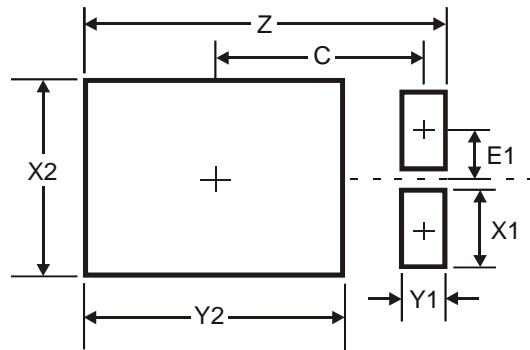

Dimensions	Value (in mm)
Z	6.6
X1	1.4
X2	3.6
Y1	0.8
Y2	4.7
C	3.87
E1	0.9

IMPORTANT NOTICE

Diodes Incorporated and its subsidiaries reserve the right to make modifications, enhancements, improvements, corrections or other changes without further notice to any product herein. Diodes Incorporated does not assume any liability arising out of the application or use of any product described herein; neither does it convey any license under its patent rights, nor the rights of others. The user of products in such applications shall assume all risks of such use and will agree to hold Diodes Incorporated and all the companies whose products are represented on our website, harmless against all damages.

LIFE SUPPORT

Diodes Incorporated products are not authorized for use as critical components in life support devices or systems without the expressed written approval of the President of Diodes Incorporated.